



Novara III

Job 2595-TO

3704 - 42 Avenue, Beaumont

1,433 sqft

9'-1" Main Floor Ceiling Height

Luxury Vinyl Plank throughout Main Floor

Side Entrance

Appliance Allowance

Quartz Countertops in Kitchen & Bathrooms

Tile in all Second Floor Bathrooms

Stand-up Shower in Ensuite

High Efficiency Furnace

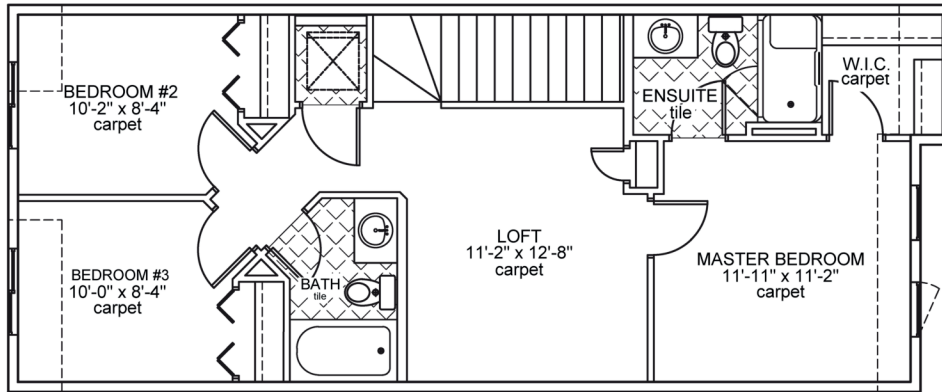

Upper Floor Area: 728 sqft

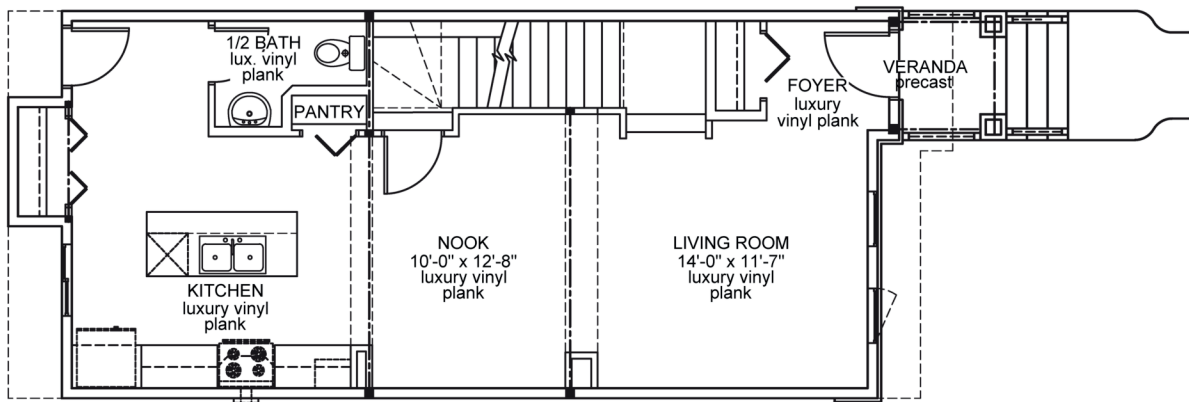

Main Floor Area: 705 sqft

JOB 2595-TO - www.montorio.ca - 780-737-1549