

# Merano II

## Job 2442-FW

17 Renwyck Place, Spruce Grove

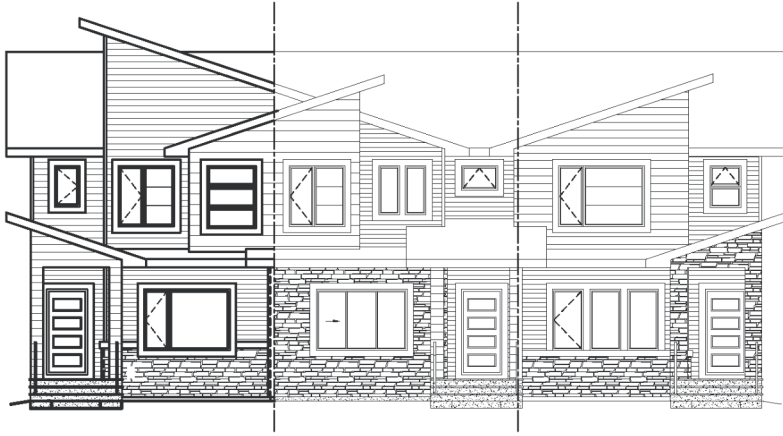

- 1,332 Sq.Ft
- 9'-1" Main Floor Ceiling Height
- Vinyl Plank throughout Main Floor
- Quartz Countertops in Kitchen & Bathrooms
- Appliance Allowance
- Side Entrance
- Double Detached Garage
- Rear Concrete Patio
- No Condo Fees
- Front & Rear Landscaping
- High Efficiency Furnace
- Super Common Wall System (Better Sound Barriers and Smell-Proof)

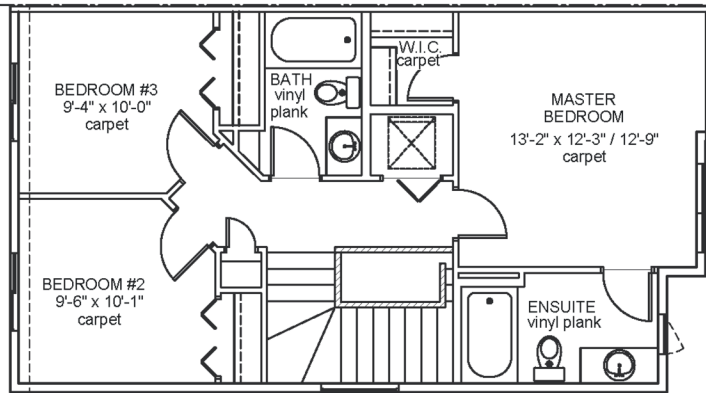

Upper Floor Area: 645 sqft

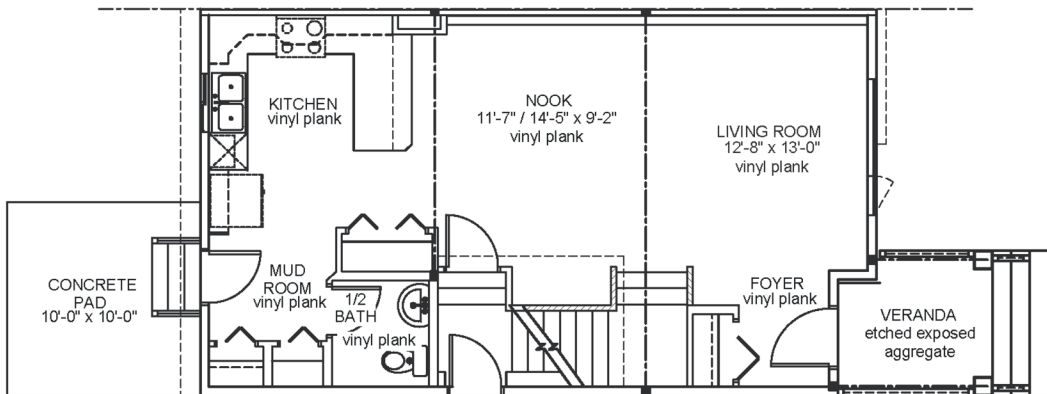

Main Floor Area: 687 sqft

JOB 2442-FW - [www.montorio.ca](http://www.montorio.ca)