



# Novara III

**Job 2458-TO**

**3708 - 42 Avenue, Beaumont**

1,433 Sq.Ft.

9'-1" Main Floor Ceiling Height

Vinyl Plank throughout Main Floor

Quartz Countertops in Kitchen & Bathrooms

Tile in all Second Floor Bathrooms

Appliance Allowance

Side Entrance

Stand-up Shower in Ensuite

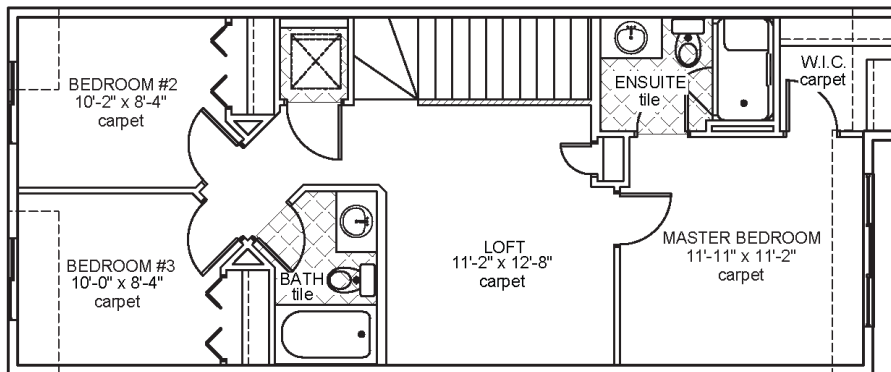

Upper Floor Area: 728 sqft

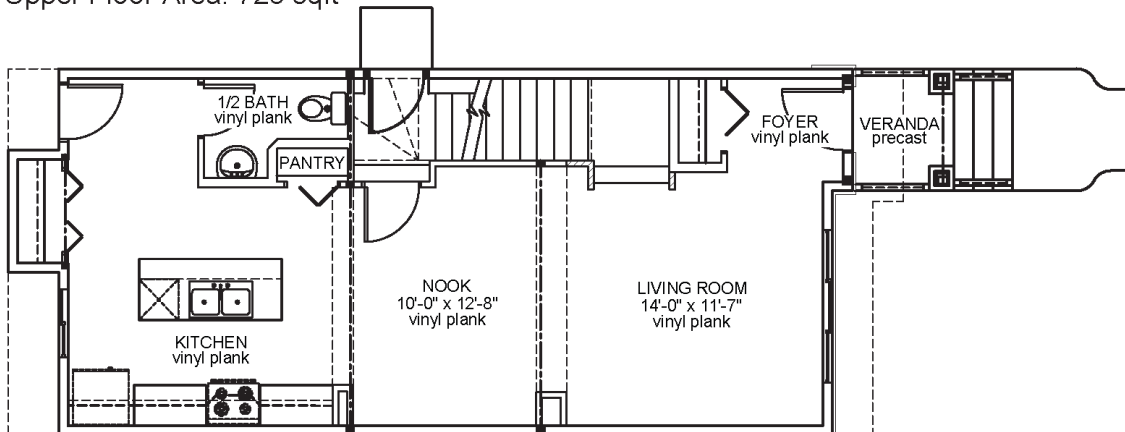

Main Floor Area: 705 sqft

